

System 3R

**Hold and go!**

**Self-Centering Vices**

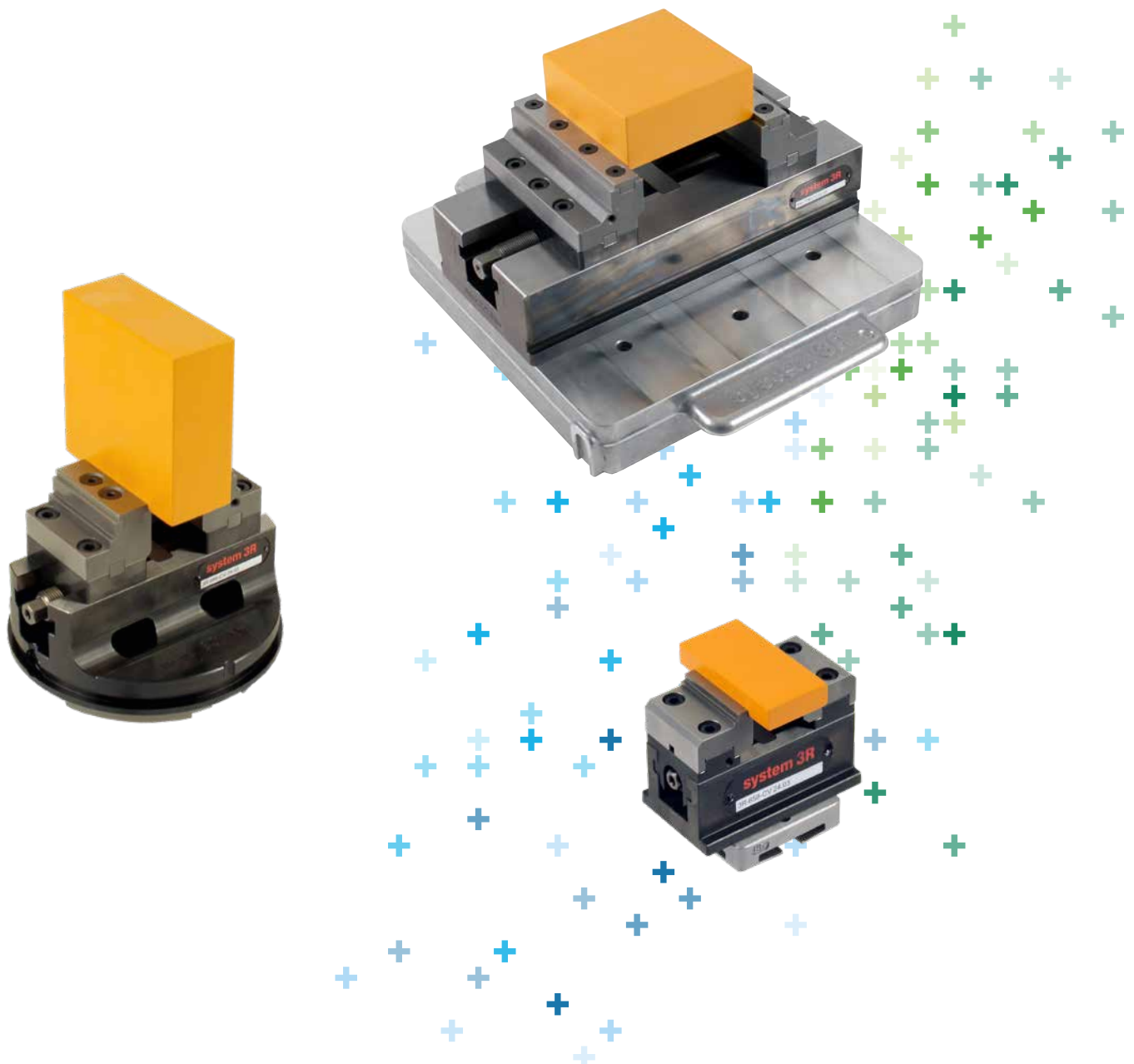

# Self-Centering Vices and accessories

**Mounted on pallets or reference elements, System 3R's self-centering machine vices offer many clear advantages:**

- High cutting performance, centering and repeat accuracy
- High clamping and holding force
- Stable, durable, one-piece construction
- Optimum accessibility
- Centric spindle bearing
- Centric clamping
- Easy cleaning.

System 3R is your unique partner to guarantee accuracy and repeatability of your clamping solution.

Easy to order.

Available immediately!

- Available on Dynafix pallets, Marco Magnum reference elements and Macro reference elements
- The centering vices are mounted with a symmetry accuracy of 0.02 mm to the reference cross of the pallet, respective the reference elements.
- The basic configuration of the vices is without clamping inserts respective clamping jaws. You can choose in between grip inserts/grip jaws for raw parts clamping inserts/ clamping jaws for 2nd /3rd side operations.

## Centering vice, Dynafix, 3R-778-CV

Centering vice on Dynafix pallet.

Choose between different inserts (not included).

- Vice length 280 mm
- Jaws width 125 mm
- Clamping length 186/246 mm
- Clamping force 50,000 N
- Weight 22.8 kg

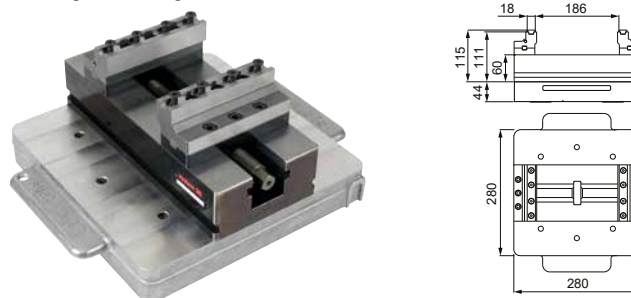

## Centering vice, MacroMagnum, 3R-688-CV

Centering vice on MacroMagnum reference element.

Choose between different inserts (not included).

- Vice length 160 mm
- Jaws width 60 mm
- Clamping length 49/93 mm
- Clamping force 30,000 N
- Weight 6.8 kg

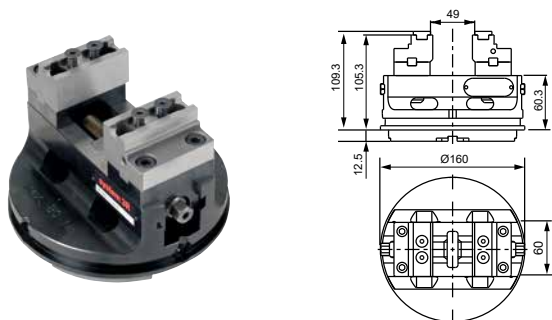

## Centering vice, Macro, 3R-658-CV

Centering vice on Macro reference element.

Choose between different jaws (not included).

- Vice length 80 mm
- Jaws width 36 mm
- Clamping length 30/78 mm
- Clamping force 16,000 N
- Weight 0.9 kg



## Accessories

### Pair of clamping inserts, Dynafix, 3R-778-J4

Clamping inserts 125 mm. Rough carbide coating. Fits on Centering vice, Dynafix, 3R-778-CV.

- Weight 0.15 kg

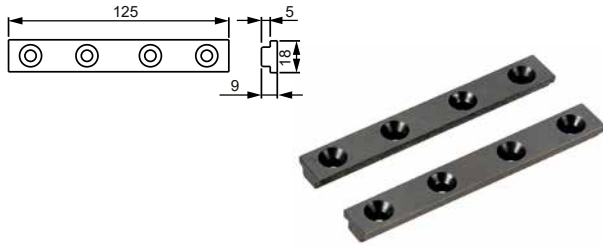

### Pair of grip inserts, Dynafix, 3R-778-J3

Grip inserts 125 mm. Fits on Centering vice, Dynafix, 3R-778-CV.

- Weight 0.15 kg

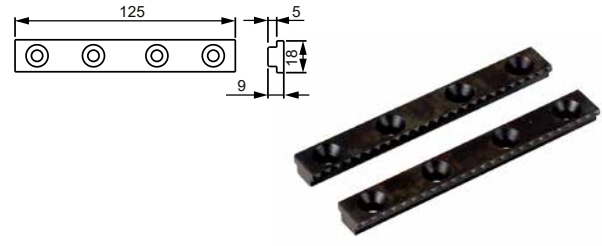

### Pair of clamping inserts, MacroMagnum, 3R-688-J4

Clamping inserts 60 mm. Rough carbide coating. Fits on Centering vice, MacroMagnum, 3R-688-CV.

- Weight 0.1 kg



### Pair of grip inserts, MacroMagnum, 3R-688-J3

Grip inserts 60 mm. Fits on Centering vice, MacroMagnum, 3R-688-CV.

- Weight 0.1 kg

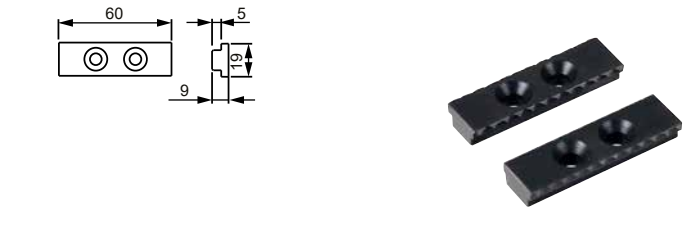

### Pair of clamping jaws, Macro, 3R-658-J2

Clamping jaws 36 mm. Fits on Centering vice, Macro, 3R-658-CV.

- Weight 0.2 kg

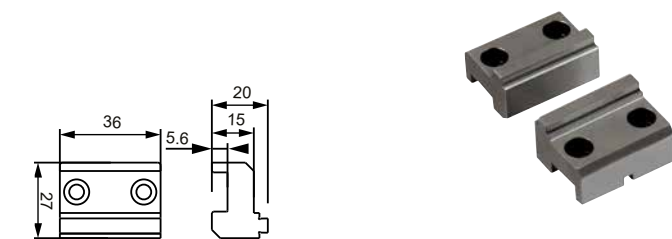

### Pair of grip jaws, Macro, 3R-658-J1

Grip jaws 36 mm. Fits on Centering vice, Macro, 3R-658-CV.

- Weight 0.2 kg

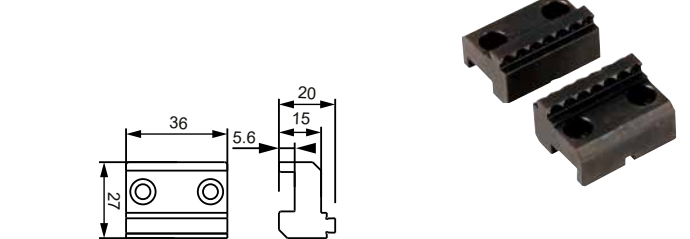

# At a glance

We enable our customers to run their businesses efficiently and effectively by offering innovative Milling, EDM, Laser, Additive Manufacturing, Spindle, Tooling and Automation solutions. A comprehensive package of services completes our proposition.

[www.gfms.com](http://www.gfms.com)

