

GF Machining Solutions

+GF+

eTRUE
True Response to User Expectation

Intelligent manufacturing solutions from CAD to part

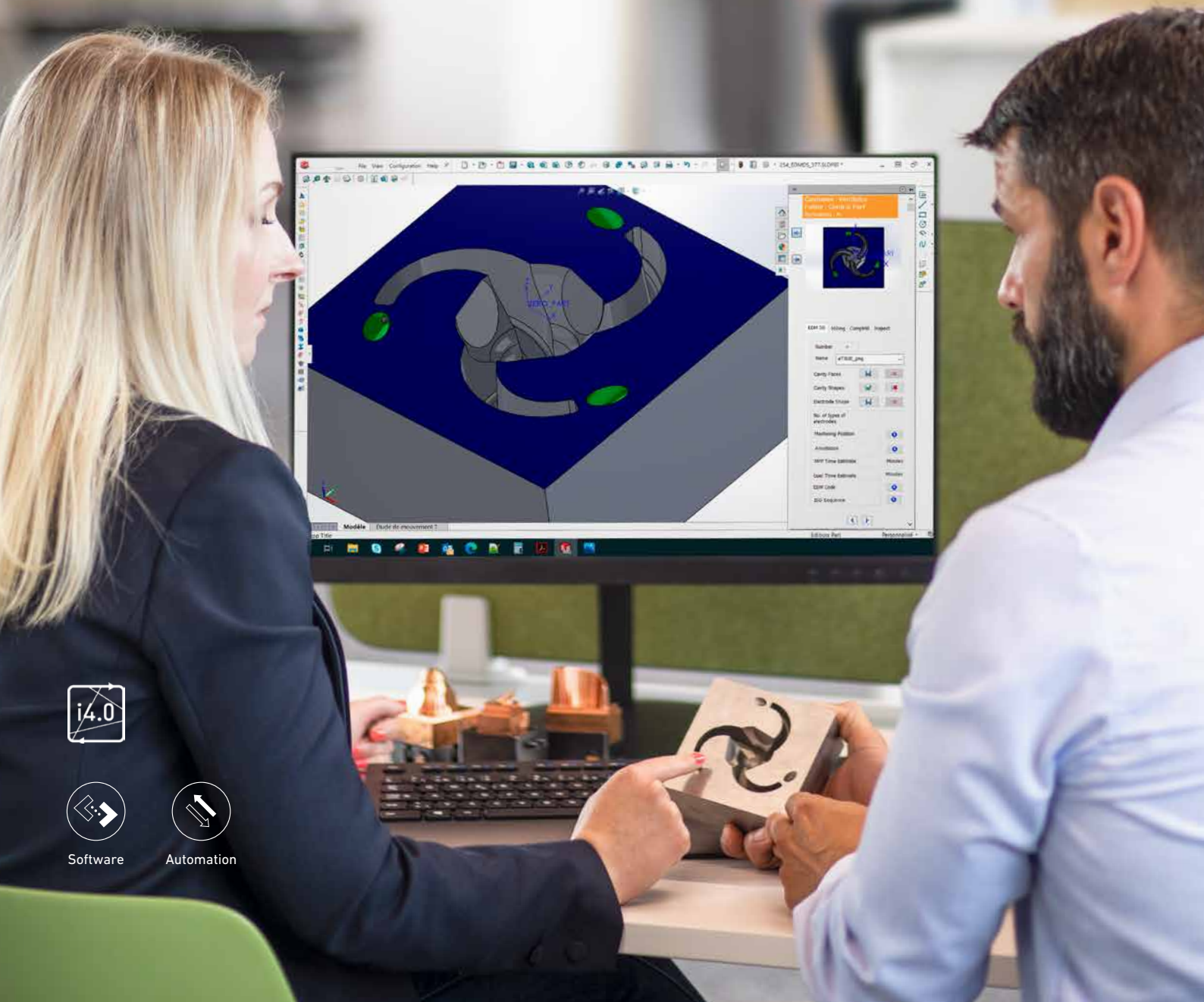

Software



Automation

Industry 4.0

eTrue (True Response to User Expectation) is the perfect digital solution combining complementary technologies, mainly for the mold and die industry, such as Milling, Die-sinking EDM, Inspection, Automation and Software, to automate the manufacturing workflow from CAD/CAM to the execution of final parts.

Automatic data flow aligned with Industry 4.0 approach



Manufacturing a part today is challenging due to the complexity of the final part and the multitude of software components and machining processes involved. In this difficult context, the intelligent eTRUE solution uses the full potential of digitalization, optimally interfacing all the involved modules.

All the processes from CAD/CAM design to execution are managed and the solution can be adapted to existing third party software modules.

At the center of the solution, the MPP (Multi-Process Preparation) Module from GF Machining Solutions ensures proper link between virtual preparation and real execution.

Modern 3d inspection treatment

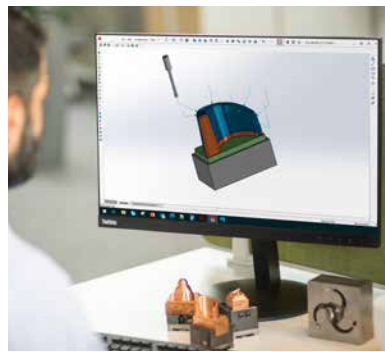

All along the manufacturing process chain, it is fundamental to know the reality in terms of geometry and accuracy and to apply necessary corrections in case of deviations.

To achieve higher accuracy, eTRUE incorporates a modern inspection approach:

- + Definition of the inspection on the CAD model during the design phase
- + Specific algorithms developed by GF Machining Solutions, for computation of data delivered by CMM

3D inspection results reflecting the real state of the component, are taken into account for the next manufacturing step thus ensuring part accuracy and reduction of scrap parts after the machining process.

CAD design and EDM process

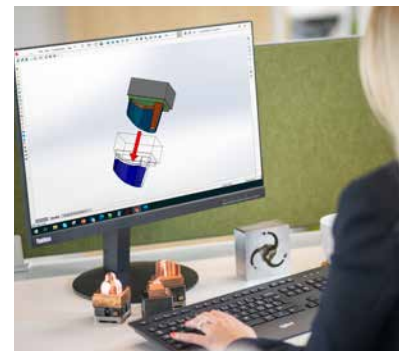

The eTRUE solution uses the real geometry description based on CAD models for the final part, electrode and for the intermediate geometry of the part before EDM (i.e. reflecting pre-milling).

Based on this accurate description, special algorithms from GF Machining Solutions, implemented into the MPP Module combine the geometry descriptions and deliver the optimum solution for EDM process execution:

- + Optimal undersize for electrode manufacturing
- + Estimated machining time for accurate planning
- + Complete Die-sinking EDM NC (numerical control) code for the execution

Highlights of the eTRUE solution

Real 3D shape treatment

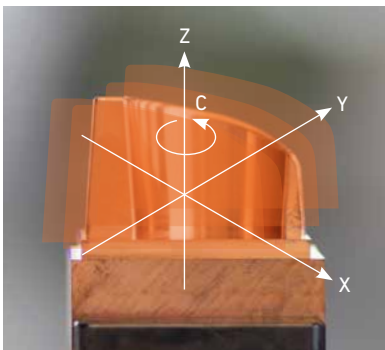

eTRUE manages the 3D CAD models throughout the global preparation to reflect reality during the manufacturing process. This approach incorporates the following elements:

- + 3D CAD models correspond to the job description during the preparation phase
- + Electrode inspection on active portion (contact areas)
- + Comparison between CAD model and actual part after inspection
- + Result of inspection transformed and adapted for Die-Sinking EDM
- + Die-Sinking process based on real electrode data and rest of material

Automate your data flow

Benefits

- + Unique single input per data
- + Facilitate machine process
- + All single process interfaced

Value

- + Save time on CAD/CAM preparation
- + Shorter machining time
- + Improve quality

Higher accuracy on final parts

Benefits

- + Automatic status of electrode quality
- + Intelligent treatment of electrode inspection

Value

- + Reduced inspection time
- + Improved accuracy
- + Increased productivity
- + Avoid scrap parts after EDM machining

Avoid human errors

Reduce inspection time

Benefits

- + Absorb CAD geometry from design
- + EDM expertise (optimal undersize) transferred to milling process

Value

- + Time saving
- + Increased productivity
- + Capability to reach performance especially for beginners

Intelligent Manufacturing

The solution delivered by eTRUE begins with CAD/CAM preparation, where the electrode study is efficiently performed and optimized by automatic computation of ideal undersize.

This quickly allows starting the electrode manufacturing by milling. In addition, the design phase provides the definition of inspection points directly on the CAD model, concentrating on the active parts of the electrode. Based on the CAD electrode shape, MPP (CAM-DS module) optimizes the Die-Sinking EDM process. Finally, MPP automatically transfers all the manufacturing data to the shop floor for job preparation and machining. Preparation time is reduced, all necessary data for machining operations is delivered, and both machining time and cost are predicted for better advanced planning.

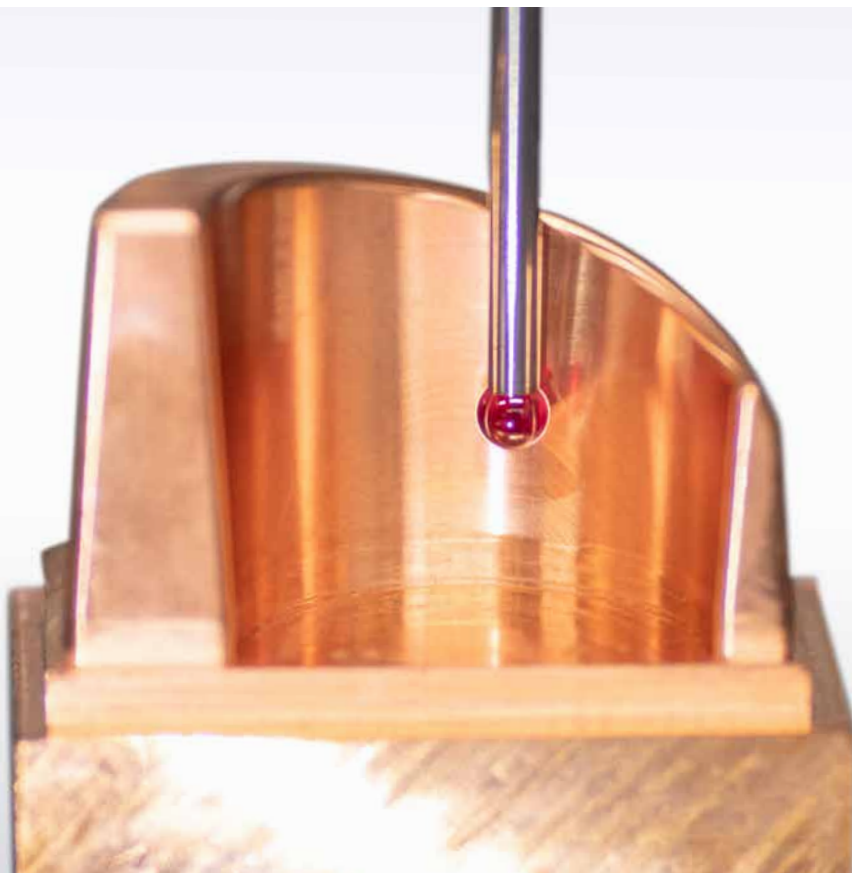
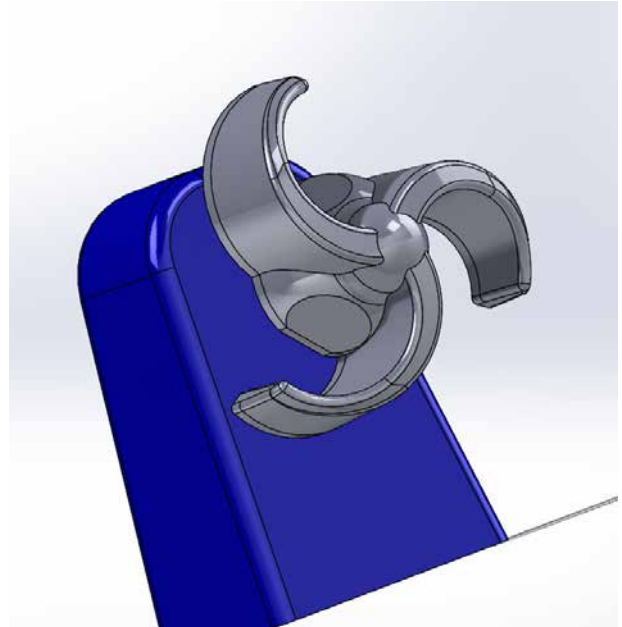

Six steps to high accuracy

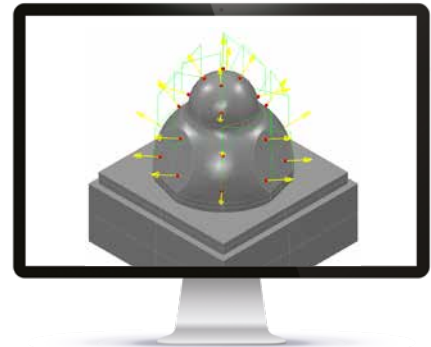
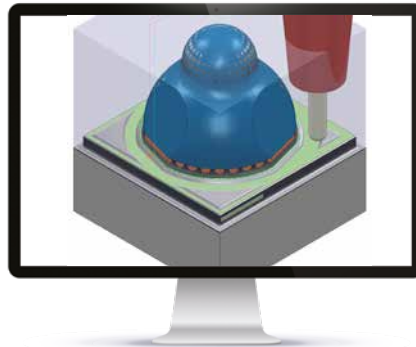
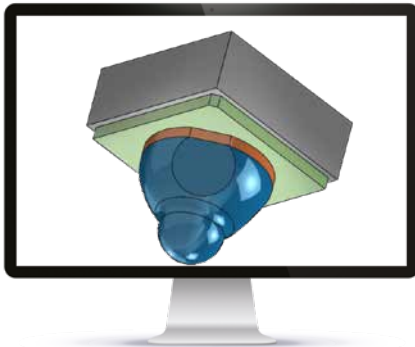
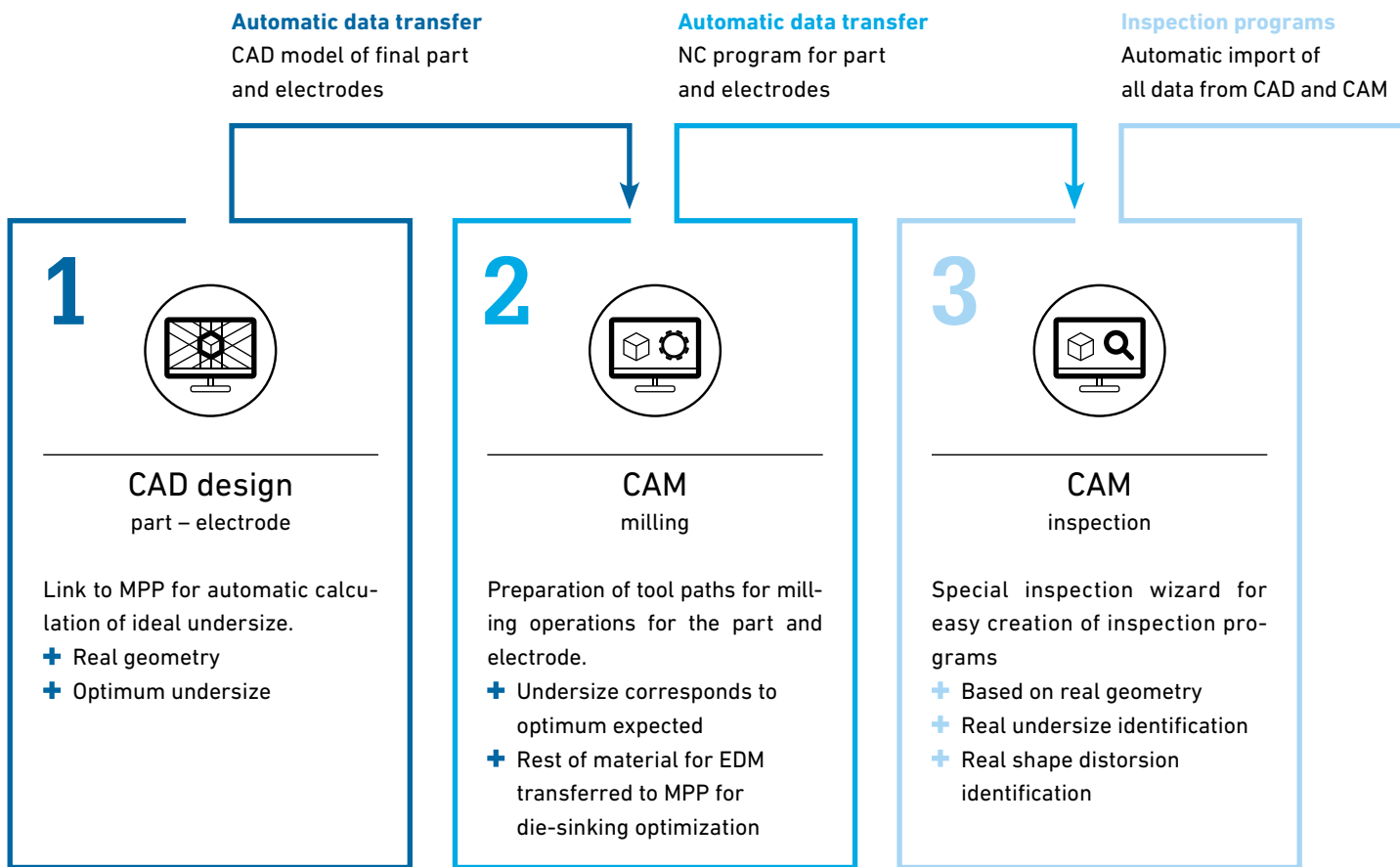

Your economic benefits with eTRUE

Your economic benefits are based on the new differentiation level achieved by a manufacturing system as a whole, exploiting single technological capacities to reach accuracy and productivity levels well above your competition.

GF Machining Solutions' portfolio

The eTRUE solution is compatible with our full portfolio of Die-sinking machines using the IPG, Milling machines, Zeiss & Hexagon CMM machines. Automation systems integrate FANUC robots to the eTRUE precision cell.

Complete manufacturing order

Automatic creation

4

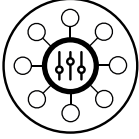

CAM DS-EDM
MPP (Multi-Process Preparation)

Prepare the NC code for Die-sinking EDM. Prepare the global manufacturing process.

- + Optimum based on real geometry
 - Electrode
 - Rest of material
- + Complete NC programs

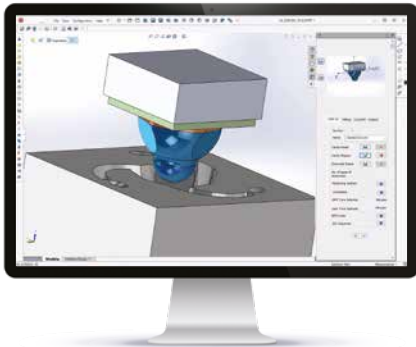

Transition from a virtual to a physical environment

Automatic data transfer

Complete manufacturing order, updated with component identification

5



Job preparation
WSM (WorkShopManager)

Automatically generated complete manufacturing order

- + Only the identification of the physical components by RFID need to be done

6

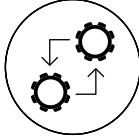

Job execution

Automatic execution in complex cells or stand-alone machines.

- + For CMM: special measurement data treatment (real off-sets, true undersize and maximum deviation)

Shopfloor

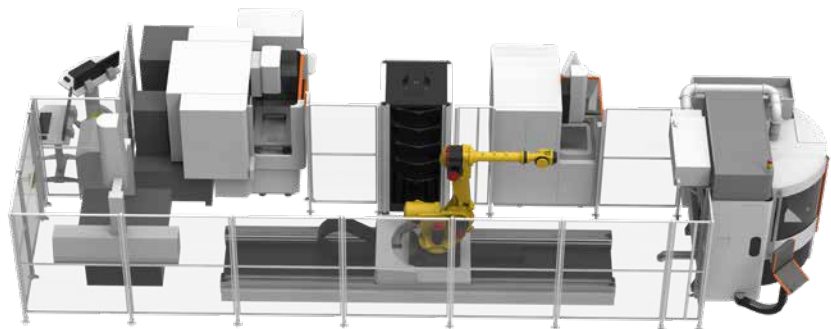

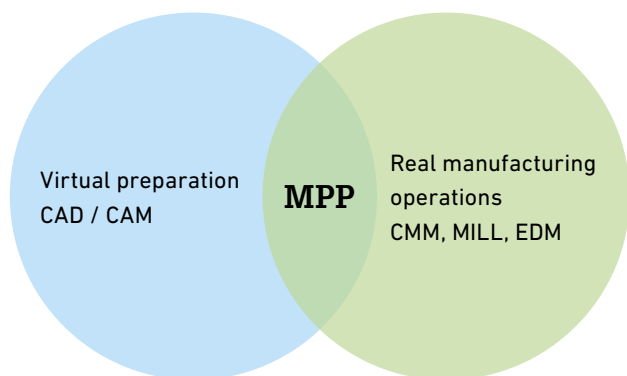

NB: MPP software features are describes in the flyer:
MPP (Multi-Process Preparation)

MPP (Multi-Process Preparation) at the heart of eTRUE

MPP reduces your preparation time, simulates final machining as well as predicts machining time and cost for better advance planning.

Discover Industry 4.0 levels of accuracy, process predictability and quality, while eliminating time-consuming and error-prone manual processes, with the MPP software at the heart of the eTRUE solution.

Values

Better productivity

Save time on CAD/CAM preparation, machining and electrode inspection.

Predictive results

Improve accuracy and quality on final parts by real accurate description and inspection CAD models.

Cost reduction

Efficient manufacturing, using full automation, automatic data flow, increased machine performances.

Manufacturing challenges

One of the key challenges in mold manufacturing, driven in particular by a huge rise in demand for mobile devices in the ICT segment, is the need for productivity increase while tightening tolerances and repeatability by using a mix of complex technologies such as EDM and high-speed milling automation systems. This context entails that automated systems, supposed to enable the leap in efficiency of equipment, require expert and time-consuming efforts to adjust multi-stage errors and are often limited in accuracy to levels which do not allow the automated mold assembly.

eTRUE solutions eliminate and compensate propagation errors during multi-stage manufacturing with hardware systems from GF Machining Solutions.

Benefits

- + Programming based on CAD models for optimized EDM code generation
- + Electrode distortion compensation from real inspection data
- + Increase overall accuracy for automatic manufacturing
- + A single process chain, with automatic data flow, that shares real geometry and real inputs



At a glance

We enable our customers to run their businesses efficiently and effectively by offering innovative Milling, EDM, Laser, Additive Manufacturing, Spindle, Tooling and Automation solutions. A comprehensive package of Customer Services completes our proposition.

www.gfms.com

